

# #7274 PANTHER<sup>®</sup> SINGLE DISC GRIND & SCRAPE<sup>™</sup>



## INSTRUCTION MANUAL

Read Manual Before Operating Machine



***National***  
Carpet Equipment, Inc.



*"Surface Preparation Solutions"*

9250 XYLON AVENUE NORTH • MINNEAPOLIS, MN 55445 • U.S.A.  
800-245-0267 • 763-535-8206 • FAX 763-535-8255 • FAX 800-648-7124  
WEB SITE: [www.nationalequipment.com](http://www.nationalequipment.com) • E-MAIL: [info@nationalequipment.com](mailto:info@nationalequipment.com)

# TABLE OF CONTENTS

■ Table of Contents .....	2
■ Rules for Safe Operation .....	3-6
A. Grounding .....	5
B. Extension Cords .....	6
■ Transportation.....	7
A. Specifications .....	7
B. Load and Unloading .....	7
■ Procedure .....	8-15
A. Handle Assembly .....	8
B. Plate Attachment.....	9
C. Plate Removal .....	9.1
D. Plate Set-Up.....	9.1
E. Machine Start Up .....	10
F. Wheel Adjustment .....	11
G. Front Wheel Assembly .....	12
H. Counter Weights .....	13
I. Motor and Overload Switch.....	13
J. Belt .....	14
K. Vacuum Port .....	15
L. Positioning Rubber Dust Guard .....	15
■ Maintenance .....	16-17
A. Maintaining Tools.....	16
B. Cleaning .....	17
C. Repairs .....	17
■ Troubleshooting .....	18
■ Complete Parts List.....	19-21
■ Part Numbers and Diagrams .....	22-28
■ Grind & Scrape™ Plates & Attachments .....	29
■ Labels .....	30
■ Guarantee.....	31
■ Return Sheet .....	32

# RULES FOR SAFE OPERATION

READ AND SAVE ALL INSTRUCTIONS FOR FUTURE USE. Before use, be sure everyone operating this equipment reads and understands this manual as well as any labels packaged with or attached to the tool.

- 1. KNOW YOUR EQUIPMENT:** Read this manual carefully to learn equipment applications and limitations as well as potential hazards associated with this type of equipment.
- 2. GROUND YOUR TOOL:** *See Grounding.*
- 3. AVOID DANGEROUS ENVIRONMENTS:** Do not use in rain, damp or wet locations, or in the presence of explosive atmospheres (gaseous fumes, dust or flammable materials). Remove materials or debris that may be ignited by sparks.
- 4. KEEP WORK AREA CLEAN AND WELL LIT:** Cluttered, dark work areas invite accidents.
- 5. DO NOT USE ON STEPS:**
- 6. DRESS PROPERLY:** Do not wear loose clothing. These may be caught in moving parts. When working outdoors, wear rubber gloves and insulated non-skid footwear. Keep hands and gloves away from moving parts.
- 7. USE SAFETY EQUIPMENT:** Everyone in the work area should wear safety goggles or glasses complying with current safety standards. Wear hearing protection during extended use and a dust mask for dusty operations. Hard hats, face shields, safety shoes, etc. should be worn when specified or necessary.
- 8. KEEP BYSTANDERS AWAY:** Children and bystanders should be kept at a safe distance from the work area to avoid distracting the operator and contacting the tool or extension cord. Operator should be aware of who is around them and their proximity.
- 9. PROTECT OTHERS IN THE WORK AREA:** Provide barriers or shields as needed to protect others from debris.
- 10. USE PROPER ACCESSORIES:** Using accessories that are not recommended may be hazardous. Be sure accessories are properly installed and maintained. Do not delete a guard or other safety device when installing an accessory or attachment.
- 11. CHECK FOR DAMAGED PARTS:** Inspect guards and other parts before use. Check for misalignment, binding of moving parts, improper mounting, broken parts and any other conditions that may affect operation. If abnormal noise or vibration occurs, turn the tool off immediately and have the problem corrected before further use. Do not use damaged equipment. Tag damaged tools "DO NOT USE" until repaired. A guard or other damaged parts should be properly repaired or replaced. For all repairs, insist on only identical National replacement parts.
- 12. REMOVE ALL ADJUSTING KEYS AND WRENCHES:** Make a habit of checking that the adjusting keys, wrenches, etc. are removed from the tool before turning it on.
- 13. GUARD AGAINST ELECTRIC SHOCK:** Prevent body contact with grounded surfaces such as pipes, radiators, ranges and refrigerators. When making cuts, always check the work area for hidden wires or pipes. Hold your tool by insulated nonmetal grasping surfaces. Use a Ground Fault Circuit Interrupter (GFCI) to reduce shock hazards.
- 14. AVOID ACCIDENTAL STARTING:** Be sure equipment is turned off before plugging it in. Do not use a tool if the power switch does not turn the tool on and off.
- 15. DO NOT FORCE EQUIPMENT:** Equipment will perform best at the rate for which it was designed. Excessive force only causes operator fatigue, increased wear and reduced control.
- 16. KEEP HANDS AWAY FROM ALL CUTTING EDGES AND MOVING PARTS.**
- 17. WEAR GLOVES WHEN CHANGING DISCS.**

# RULES FOR SAFE OPERATION

18. **DO NOT ABUSE CORD:** Never unplug by yanking the cord from the outlet. Pull plug rather than cord to reduce the risk of damage. Keep the cord away from heat, oil, sharp objects, cutting edges and moving parts.
19. **DO NOT OVERREACH. MAINTAIN CONTROL:** Keep proper footing and balance at all times. Maintain a firm grip.
20. **STAY ALERT:** Watch what you are doing, and use common sense. Do not use when you are tired, distracted or under the influence of drugs, alcohol or any medication causing decreased control.
21. **STARTING MACHINE:** On/off switch must be in off position before connecting to power source.
22. **UNPLUG EQUIPMENT:** When it is not in use, unplug tool before changing accessories or performing recommended maintenance.
23. **MAINTAIN EQUIPMENT CAREFULLY:** Keep handles dry, clean and free from oil and grease. Keep cutting edges sharp and clean. Follow instructions for lubricating and changing accessories. Periodically inspect tool cords and extension cords for damage. Have damaged parts repaired or replaced.
24. **STORE IDLE EQUIPMENT:** When not in use, store in a dry, secured place. Keep away from children.
25. **MAINTAIN LABELS AND NAMEPLATES:** These carry important information. If unreadable or missing, contact National for a free replacement.
26. **MACHINE IS HEAVY, DO NOT DROP:** Counter weights are heavy. Take caution when removing or reassembling.

**⚠ WARNING:** Exposure to dust may cause respiratory ailments. Use approved NIOSH or OSHA respirators, safety glasses or face shields, gloves and protective clothing. Provide adequate ventilation to eliminate dust, or to maintain dust level below the Threshold Limit Value for nuisance dust as classified by OSHA.

**⚠ WARNING:** Failure to follow any of the above instructions could cause damage to machine, damage to property or serious bodily injury or death.

## **⚠ WARNING: SILICA DUST WARNING**

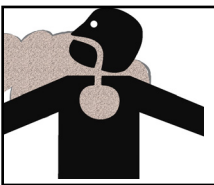

Grinding/cutting/drilling of masonry, concrete, metal and other materials can generate dust, mists and fumes containing chemicals known to cause serious fatal injury or illness, such as respiratory disease, cancer, birth defects or other reproductive harm. If you are familiar with the risks associated with the particular material being cut, review the material safety data sheet and/or consult you employer, the material manufacturer/supplier, governmental agencies such as OSHA and NIOSH and other sources of hazardous materials. California and some other other authorities, for instance, have published lists of substances known to cause cancer, reproductive toxicity, or other harmful effects. Control dust, mist and fumes at the source where possible. In this regard use good work practices and follow the recommendations of the manufacturer/supplier, OSHA/NIOSH, and occupational and trade associations. When the hazards from inhalation of dust, mists and fumes cannot be eliminated, the operator and any bystanders should always wear a respirator approved by OSHA/MSHA for the material being cut.

# RULES FOR SAFE OPERATION

## GROUNDING

**⚠ WARNING:** Improperly connecting the grounding wire can result in the risk of electric shock. Check with a qualified electrician if you are in doubt as to whether the outlet is properly grounded. Do not modify the plug provided with the tool. Never remove the grounding prong from the plug. Do not use the tool if the cord or plug is damaged. If the plug will not fit the outlet, have a proper outlet installed by a qualified electrician.

**⚠ WARNING:** Electrical cords can be hazardous. Misuse can result in fire or death by electrical shock. Read carefully and follow all directions.

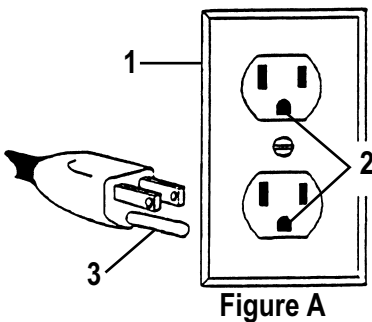

1. Cover of grounded outlet box
2. Outlet ground
3. Grounding prong
4. Temporary adapter
5. Screw
6. Green grounding ear

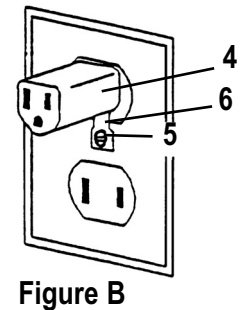

### GROUNDING TOOLS: TOOLS WITH THREE PRONG PLUGS

Tools marked "Grounding Required" have a three wire cord and three prong grounding plug. The plug must be connected to a properly grounded outlet. See *Figure A*. If the tool should electrically malfunction or break down, grounding provides a low resistance path to carry electricity away from the user, reducing the risk of electric shock.

The grounding prong in the plug is connected through the green wire inside the cord to the grounding system in the tool. The green wire in the cord must be the only wire connected to the tool's grounding system and must never be attached to an electrically "live" terminal.

Your tool must be plugged into an appropriate outlet, properly installed and grounded in accordance with all codes and ordinances. The plug and outlet should look like those in *Figure A*.

*Figure B* illustrates a temporary adapter available for connecting grounded plugs (*Figure A*) to two prong outlets. The green rigid ear or lug extending from the adapter must be connected to a permanent ground such as a properly grounded outlet box or receptacle. Simply remove the center screw from the outlet, insert the adapter and reattach the screw through the green grounding ear to the outlet. If in doubt of proper grounding, call a qualified electrician. A temporary adapter should only be used until a properly grounded outlet can be installed by a qualified electrician. The Canadian Electrical Code prohibits the use of temporary adapters.

# RULES FOR SAFE OPERATION

## EXTENSION CORDS

**⚠ WARNING:** Electrical cords can be hazardous. Misuse can result in fire or death by electrical shock. Read carefully and follow all directions.

Grounded tools require a three wire extension cord. Double insulated tools can use either a two or three wire extension cord. As the distance from the supply outlet increases, you must use a heavier gauge extension cord. Using extension cords with inadequately sized wire causes a serious drop in voltage, resulting in loss of power and possible tool damage.

The smaller the gauge number of the wire, the greater the capacity of the cord. For example, a 14 gauge cord can carry a higher current than a 16 gauge cord. When using more than one extension cord to make up the total length, be sure each cord contains at least the minimum wire size required. If you are using one extension cord for more than one tool, add the nameplate amperes and use the sum to determine the required minimum wire size.

### GUIDELINES FOR USING EXTENSION CORDS

- If you are using an extension cord outdoors, make sure it is marked with the suffix "W-A" ("W" in Canada) to indicate that it is acceptable for outdoor use.
- Be sure your extension cord is properly wired and in good electrical condition. Always replace a damaged extension cord or have it repaired by a qualified person before using it.
- Protect your extension cords from sharp objects, excessive heat and damp or wet areas.
- Keep away from water. Do not use if wet.  A circular icon with a diagonal slash through it, containing a water droplet, indicating that the equipment should not be used if wet.
- Inspect thoroughly before each use. **DO NOT USE IF DAMAGED.**
- Make sure equipment is OFF before connecting cord outlet.
- FULLY INSERT plug into outlet.
- Do not remove, bend or modify any metal prongs or pins of cord.
- Do not use excessive force to make connections.
- Do not connect a three prong plug to a two-hole cord.
- Avoid overheating. Uncoil cord and do not cover it with any material.
- Do not walk on cord.
- Do not drive, drag or place objects over cord.

**READ AND SAVE ALL INSTRUCTIONS FOR FUTURE REFERENCE.**

# TRANSPORTATION

## SPECIFICATIONS

SPECIFICATIONS		#7274
Length:	40"	
Width:	21"	
Height:	44"	
Weight (machine only):	267 lbs.	
MOTOR INFORMATION		
RPM:	280	250
Volts:	110	220
HP:	1½	
Amps-Full Load:	14.4	
Continuous Duty		

## LOAD AND UNLOAD

- Remove counter weight and disk before loading or unloading.
- Always disconnect from power source before transporting.
- Loosening Handle Securing "T" Bolts to slide handle down to make machine easier to load. Retighten "T" Bolts when handle is at the desired height.
- Disconnecting handle cord from the motor plug cord and the handle can be removed to make machine more compact.

# PROCEDURE

## HANDLE ASSEMBLY

**⚠ WARNING:** Handle must be engaged with both securing "T" bolts. Failure to do so could cause serious injury.

Handle allows for 12" of adjustment depending on operator height. Insert handle (See Figure A) to desired length and properly tighten both locking "T" bolts (See Figure B). Plug handle cord into motor cord (See Figure C). Make sure both "T" Bolts engage handle at all times.



Figure A

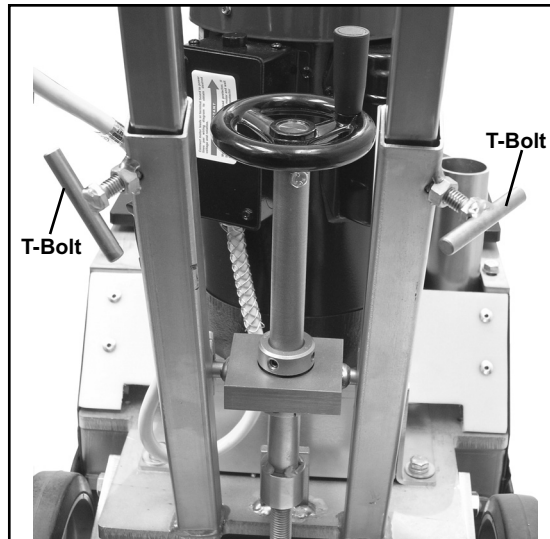

Figure B

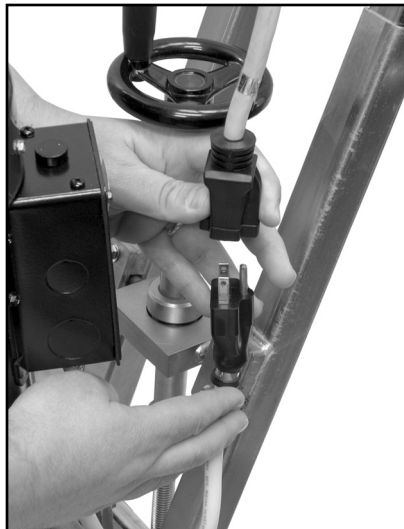

Figure C



# PROCEDURE

## PLATE ATTACHMENT

Many choices of plates are available for: scraping, grinding, sanding, polishing, scrubbing etc.

**⚠ WARNING:** Never operate machine with plate or disc attachment that is not rated at a minimum of 300 RPM.

Never operate machine with plate larger than 16" in diameter or plate protruding outside of machine covering or guards. Failure to do so could cause damage to machine or serious injury.

Never change plate machine before unplugging machine from power source. Failure to do so could cause damage to machine or serious injury.

If machine is too heavy, front counter weight can be removed for easier handling.

To expose the underside of the machine, turn machine on to side (See Figure A).

ALWAYS attach plate by hand, NEVER by placing machine over an unattached plate and starting machine to lock plate. Doing this could cause severe damage to plate and/or drive hub.

Select desired plate type. Position the three slots on the clutch plate over the three lugs of the drive hub (See Figure B). Turn the plate counterclockwise as far as it will go. The plate is now secure.

**⚠ WARNING:** When machine is tilted on its side never operate machine with the plate exposed. Serious injury and possible plate disengagement could occur.

When setting machine down into operation position, hold machine firmly. Set down gently, DO NOT drop. Damage to plate and machine could occur if dropped.

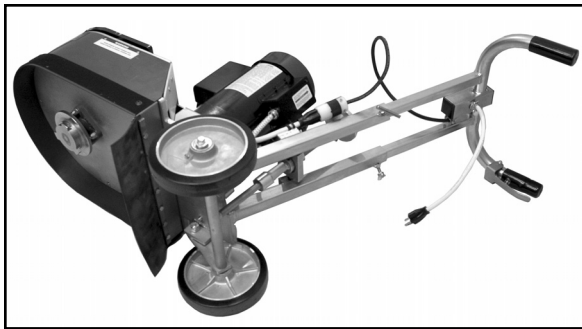

Figure A

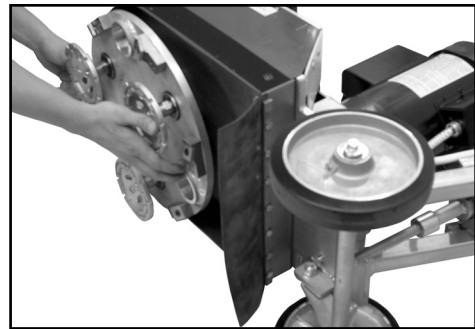
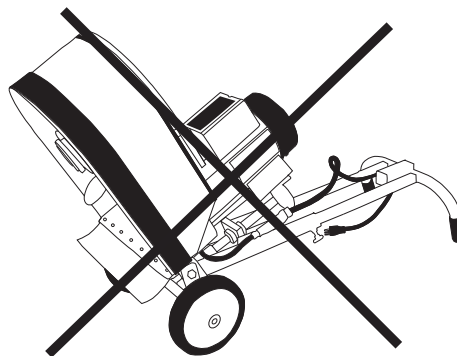

Figure B



**DO NOT** lean or tilt machine on back handle.

**⚠ WARNING:** This machine is designed to run discs or plates with a 3-1/4" clutch plate and no larger than a 15" in diameter or no smaller than 10" in diameter. Make sure the manufacturers attachments are specified and/or rated for the proper operation of this machine.

# PROCEDURE

## PLATE REMOVAL

Turn plate clockwise. Disengage drive hub lugs. Remove plate.

## PLATE SET-UP DIAMOND GRINDING DISCS

Unique planetary diamond grinding disc rotates on heavy-duty sealed bearings which allow the disc to rotate in the opposite direction of the plate eliminating “swirl marks” in concrete surfaces • Presents the same result as a planetary grinder costing thousands of dollars more • Gives the surface of the floor a fantastic finish for sealing, painting or staining.



## PLATE SET-UP DIAMOND GRINDING PLUGS

Diamond grinding plugs for aggressive grinding • Evens out, smooths or decontaminates concrete surfaces.



## PLATE SET-UP CARBIDE CHIPS

This unique three-position carbide mount allows operator to set carbides to optimum performance • For scraping all types of adhesives, removing thin-set mortar, epoxy, urethane, thin coatings, elastomerics, paint, etc.

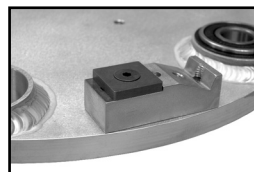

*Chip set: flat, straight*

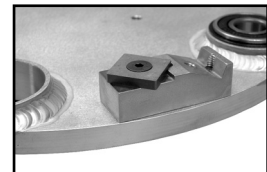

*Chip set: flat, point forward*

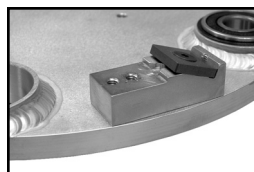

*Chip set: angle, straight for aggressive scraping*

# PROCEDURE

## MACHINE START UP PROCEDURE

### TO RUN MACHINE

1. Machine **MUST** be off before plugging machine into power source.
2. Plug power cord into proper size extension cord.
3. Plug power cord into outlet.
4. Plug the motor cord plug into the handle cord plug if not connected.
5. Depress handle to relieve pressure from the plate to the floor. If possible, start in a clean floor area. Once started, let plate contact floor with full pressure. Failure to do so could cause damage to the motor.
6. Depress lever on handle, motor will run.
7. Release lever for motor to stop.

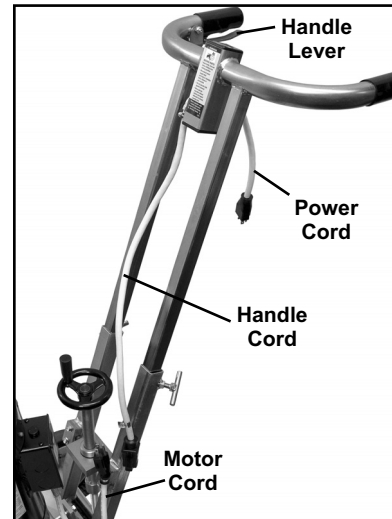

Figure A

**⚠ WARNING:** DO NOT lock lever on handle into a permanent on position. If operator would lose control or be disabled, machine continues to operate.

**⚠ WARNING:** DO NOT leave a plugged-in machine unattended.

Improper connection of the equipment-grounding conductor can result in a risk of electrical shock. Check with a qualified electrician or service person if you are in doubt as to whether the outlet is properly grounded. DO NOT modify the plug provided with this unit. If it will not fit the outlet, have a proper outlet installed by a qualified electrician. NOTE: In Canada, the use of a temporary adapter is not permitted by the Canadian Electrical Code.

Improper use of the grounding plug can result in a risk of electrical shock.

Know what you are removing. Scraping, sanding or grinding can release health hazardous dust and liquids. Make sure you are following OSHA, State and/or Federal guidelines when removing hazardous materials. Take necessary precautions and procedures. On some materials, grinding, scraping or sanding are not allowed.

# PROCEDURE

## WHEEL ADJUSTMENT

Unlike a buffer, the wheels are adjustable in height, which allows for total, partial or no engagement of the wheels to the floor.

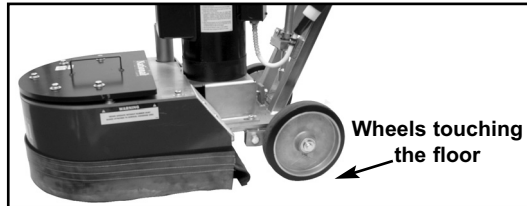

Engaged

Rotating the angle adjustment wheel (See Figure A) clockwise raises the wheels, disengaging them from the floor. Rotating the angle adjustment wheel counterclockwise lowers the wheels, engaging them to the floor (See Figure B). Experiment with the angle to see what works the best for the application.

On tough removal (ie: thin-set mortars), leaving wheels engaged to the floor allows the weight of the machine to be on the wheels using a pivoting motion, which gives the operator more control and less fatigue.

For buffing, polishing, scrubbing, light scraping (ie, dry glue), disengage wheels to allow for heel-toe movement of machine for an operation action like a buffer. With wheels disengaged, raise handle slightly. Machine will move to the right. Push down on handle, machine will move to the left.



Figure A



Figure B

# PROCEDURE

## FRONT WHEEL ASSEMBLY

The front wheels allow for a milling or skimming action to take place.

Bolt front wheel assembly to machine in holes using the provided 3/8 bolts (See Figure A).

Front wheels adjust independently leveling, stabilizing the machine or allowing pressure on disc to be set at any position around the circumference of the disc (See Figure B).

Keep the weight of the machine from allowing the plate to dig into the floor surface too aggressively. Reducing weight allows the machine to work easier with difficult material on extremely rough floors or soft subfloors.

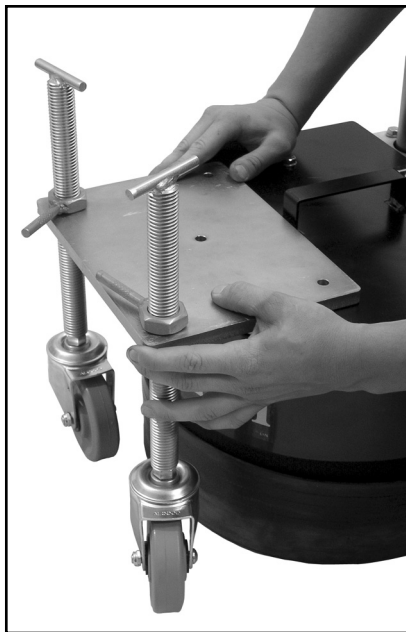

Figure A



Figure B

# PROCEDURE

## COUNTER WEIGHTS

Machine comes standard with a 24 pound counter weight, which can be removed. The total weight of the machine with the counter weight is 160 pounds.

To remove the counter weight, remove the five 3/8 bolts on the top of the counter weight (See Figure B). Use caution when removing or mounting.

**⚠ WARNING:** DO NOT add additional weight beyond the supplied weight. This will cause damage to the motor and make machine unpredictable in handling.

**NOTE:** If the motor continually overloads, remove the counter weight or check power cord or circuit.



Figure A

## MOTOR AND OVERLOAD SWITCH

The powerful, 1 ½ HP sealed motor is protected by an overload switch. The overload switch is designed to cut out when motor is over stressed to avoid damage to the motor. If the overload is tripped, let the machine rest and cool down. Push overload reset button (See Figure B). Restart machine. **NOTE:** Overload will not reset until the machine is properly cooled down. **NOTE:** If the machine continues to overload, remove the counter weight or change to a less aggressive plate.



Figure B

# PROCEDURE

## BELT

The machine uses a 520J10 Bando belt.

### TO REMOVE OR CHANGE BELT

Unplug machine from power source. Remove counter weight. Remove Cover. Loosen four bolts on the motor base (See Figure A). Loosen belt tension bolt (rear of machine) (See Figure B) and remove belt . Replace belt. Retighten tension bolt. Make sure the belt is in proper alignment between the two pulleys (See Figure C). When proper tension on the belt is achieved, retighten the four motor base bolts. Replace the cover. Replace counter weight if needed.

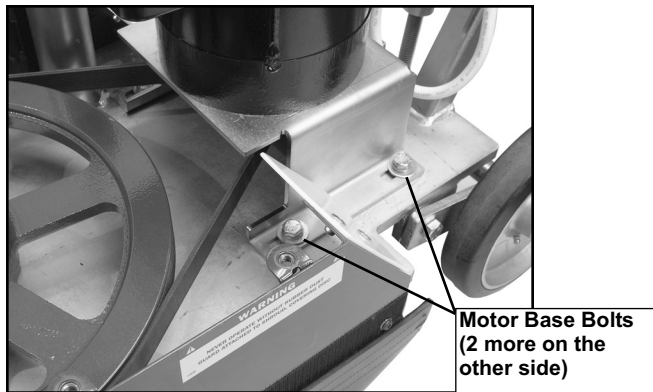

Figure A

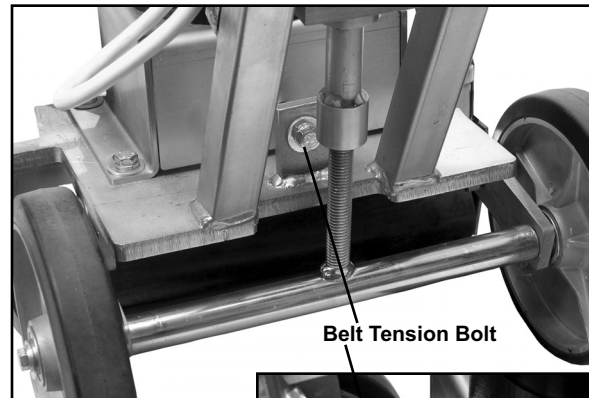

Figure B



Figure C

**⚠ WARNING:** Never run machine without protective cover. Failure to do so could cause serious injury.

# PROCEDURE

## VACUUM PORT

The machine is provided with a vacuum port at the rear of the machine (See Figure A). Use a vacuum hose that snugly fits either on the outside or the inside of the port. The outside diameter of the port is 2". The inside diameter of the port is 1 ¾". This port will pick up dust but not all heavy or large particles.

**⚠ WARNING:** Make sure you are using the proper style of vacuum for what you are grinding, scraping or sanding. Failure to do so could cause emissions of hazardous particulates or explosion due to fine dust (ie, wood sanding), which is flammable. Make sure the system you are using complies or exceeds OSHA recommended standard. Make sure the rubber dust guard is covering all the way to the floor surface.

## POSITIONING RUBBER DUST GUARD

**⚠ WARNING:** NEVER operate machine without rubber guard in place covering plate completely. Failure to do so could cause serious injury.

NEVER mount or readjust rubber guard with machine plugged in. Disconnect from power source before mounting or readjusting the rubber guard.

Unplug machine from power source. With machine sitting in the operating position, remove rubber dust guard held on by Velcro. Starting at one end of the shroud, place guard to rest on floor surface (See Figure B). Firmly press rubber guard into securing Velcro on shroud. Wrap rubber guard all the way around the shroud making sure the guard rests on the floor surface and is secure.

If rubber guard securing Velcro becomes loaded up with debris, wash out with mild soap or blow out with an air hose. If Velcro on the machine is damaged or worn out, replace before using the machine. If the rubber guard is cut, damaged or worn out, replace before using the machine.

Safety glasses need to be worn by operator and all people working around the equipment.

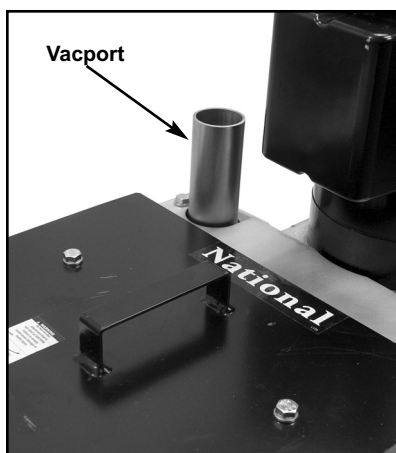

Figure A

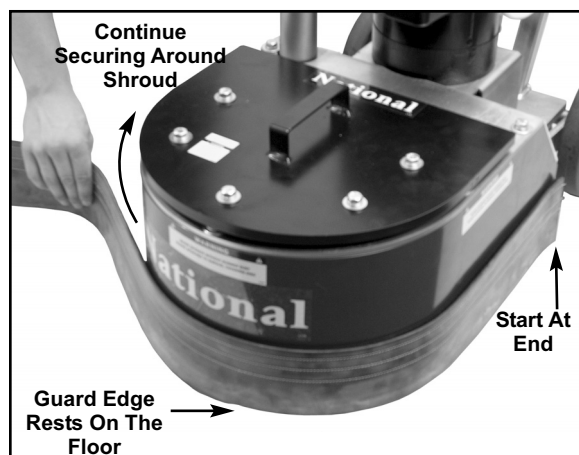

Figure B





# MAINTENANCE

## MAINTENANCE

A well-maintained machine is a productive machine. If not properly maintained, it could be unsafe and could break down. A scheduled maintenance program should insure a long system life and a safe work environment.

1. Always wear eye protection.
2. Keep flammable and fragile objects away from the tool.
3. Always check nuts and bolts to make sure they are tight.
4. Always use the tool with proper voltage specified on the machine's nameplate.
5. Always keep guards in place.
6. Do not operate around water or wet conditions without use of GFI on cord.
7. Use properly grounded cord and receptacle.
8. Unplug from power before servicing.
9. Use 12 gauge or heavier wire cord, not exceeding 50 feet in length.
10. Do not force machine.
11. Do not alter machine.
12. Keep wheels free from debris.
13. Maintain Labels. These carry important information. If unreadable or missing, contact National for a free replacement.

 **WARNING:** DO NOT lock switch on handle into a permanent on position. If operator would lose control or be disabled, machine continues to operate.

 **WARNING:** To reduce the risk of injury, always unplug your tool before performing any maintenance. Never disassemble the tool or try to do any rewiring on the tool's electrical system. Contact National for ALL repairs.

## MAINTAINING TOOLS

Keep your tool in good repair by adopting a regular maintenance program. Before use, examine the general condition of your tool. Inspect guards, switches, tool cord set and extension cord for damage. Check for loose screws, misalignment, binding of moving parts, improper mounting, broken parts and any other condition that may affect its safe operation. If abnormal noise or vibration occurs, turn the tool off immediately and have the problem corrected before further use. Tag damaged tool, "DO NOT USE" until repaired (See Repairs).

- Mechanical inspection and cleaning (pulleys, belts, bearings, nuts, bolts, housing, labels, etc.).
- Electrical inspection (switch, cord, plugs, etc.).
- Testing to assure proper mechanical and electrical operation.

# MAINTENANCE

## CLEANING

Clean dust and debris from wheels and housing. Keep the tool handles clean, dry and free of oil or grease. Use only mild soap and a damp cloth to clean your tool since certain cleaning agents and solvents are harmful to plastics and other insulated parts. Some of these include: gasoline, turpentine, lacquer thinner, paint thinner, chlorinated cleaning solvents, ammonia and household detergents containing ammonia. Never use flammable or combustible solvents around machinery.

- If using pressure washer, do not directly spray motor or on/off switch.
- Never use machine wet. Dry off completely before use.
- Replace missing or worn labels. Labels contain important safety and operational information.

**⚠ WARNING:** To reduce the risk of injury, electric shock and damage to the tool, never immerse your tool in liquid or allow a liquid to flow inside the tool.

## REPAIRS

If your tool is damaged, call for a return/repair authorization number and return to:

National Carpet Equipment, Inc.  
9250 Xylon Avenue North  
Minneapolis, MN 55445  
(763) 535-8206 • 800-245-0267

- Shipments are not accepted without a return authorization number
- COD or freight collect shipments will not be accepted

# TROUBLESHOOTING

## **ALWAYS DISCONNECT MACHINE FROM POWER SOURCE BEFORE SERVICING**

### **MACHINE IS HARD TO HANDLE**

1. Remove the counterweight.
2. Change to a less aggressive cutting bit.
3. Allow wheels of machine to engage the floor to create drag.

### **MACHINE IS OVERLOADED**

1. Let machine rest and cool down. Reset overload button on motor.
2. Remove the counterweight.
3. Check power cord. Use a 12 gauge or heavier cord, 50' or less.

### **DEBRIS IS COMING OUT FROM THE BOTTOM OF THE MACHINE**

1. Check rubber guard to make sure it is mounted and secured properly. The bottom edge of the rubber guard should be touching the floor.

### **BLOWS FUSES OR CIRCUIT BREAKERS**

1. Check and/or change attached power cord. Use a 12 gauge cord, 50' or less.
2. Move to a different outlet or a better circuit.
3. Reduce machine weight.
4. Use a less aggressive disc selection.

### **MOTOR WILL NOT RUN**

1. Check for a blown fuse and/or circuit breaker at the electrical panel.
2. Overload switch has been tripped.
3. Defective switch in handle.
4. Defective power cord.

### **NOISY OR EXCESSIVE VIBRATION**

1. Defective motor. Contact National for service.
2. Bad belt or belt needs maintenance. Retighten or change the belt.
3. Improper cutter selection.
4. Disc or plate is out of balance. Change plate or rebalance.
5. An incorrect adapter on the plate or disc. Change to a different adapter specified for the job type.

# COMPLETE PARTS LIST

<u>PART #</u>	<u>DESCRIPTION</u>
63-P30	3/8" SMALL WIRE CLAMP (2)
550-5B	SHAFT COLLAR 7/8"
550-12	ADJUSTMENT WHEEL W/ HANDLE ONLY
6274-166	HANDLE WIRED COMPLETE (NOT SHOWN)
6274-166D	HANDLE END CAP (SQUARE) (2)
6274-166G	HANDLE SWITCH PLATE
6274-166H	HANDLE CONTROL LEVER
6274-171	POWER CORD
6274-172	POWER CORD - MALE PLUG
6274-173	HANDLE CORD - FEMALE PLUG
6274-178A	RUBBER GUARD MOUNTING VELCRO, LOOP SIDE 50" (NOT SHOWN)
6274-178B	RUBBER GUARD MOUNTING VELCRO FOR SHROUD, HOOK SIDE 50" (NOT SHOWN)
6274-191	HANDLE SWITCH
6280-147-1	STARTER SWITCH
6280-148	MOTOR FAN COVER
6280-148A	MOTOR FAN COVER SCREW (3)
6280-149	MOTOR FAN (NOT SHOWN)
6280-150	CAPACITOR COVER
6280-152	MOTOR JUNCTION BOX ONLY (NOT SHOWN)
6280-152-1	MOTOR JUNCTION BOX COVER ONLY
6280-152-3	MOTOR JUNCTION COVER GASKET (NOT SHOWN)
6280-152-4	MOTOR JUNCTION BOX FRAME GASKET (NOT SHOWN)
6280HD-200	MOTOR JUNCTION BOX
6280HD-201	THERMO-OVERLOAD SWITCH
6280HD-202	MOTOR CAPACITOR (RUN) (2)
6280HD-203	MOTOR CAPACITOR (START)
6280HD-204	CAPACITOR COVER
6280HD-204A	CAPACITOR COVER GASKET (NOT SHOWN)
7274-2	SHROUD
7274-4	ADJUSTMENT T-BAR
7274-5	BEARING PLATE
7274-6	ADJUSTMENT SHAFT
7274-7	WHEEL LEGS (2)
7274-8	TOP WEIGHT
7274-9	FRONT WHEEL BRACKET
7274-10	HANDLE BAR ASSEMBLY
7274-11	ADJUSTMENT WHEEL ASSEMBLY
7274-12	MOTOR MOUNT
7274-13	AXLE
7274-23	SMALL PULLEY
7274-24	LARGE PULLEY
7274-25	BELT 520J10
7274-28	GRINDER HUB
7274-29	REAR BRACKET ASSEMBLY
7274-31	BRACKET COVER (2)
7274-35	JAMB NUT (2)
7274-36	1" PLASTIC TUBE
7274-89	FRONT WHEEL ASSEMBLY
7274-90	CASTER WHEEL (2)
7274-91	FRONT ADJUSTMENT ROD (2)
7274-100	BASE PLATE
7274-138	COVER

# COMPLETE PARTS LIST

## COMPLETE PARTS LIST (continued)

<u>PART #</u>	<u>DESCRIPTION</u>
7274-177	RUBBER GUARD (W/ LOOP VELCRO)
7274-200	WHEEL (2)
71101	BEARING 7/8"
71111	FLANGE BEARING (2)
72362	MOTOR 115 VOLT
72901	O RING - #113
73001	1/4-20 X 1/2 WIZLOCK BOLT (4)
73002	1/4 SPLIT WASHER (FRAME & SHROUD PARTS-5, REAR BRACKET-2)
73003	1/4-20 X 5/8 BUTTON HEAD SCREW (5)
73006	1/4-20 X 3/4 BUTTON HEAD SCREW (2)
73008	1/4-20 NYLON LOCK NUT (ADJUSTMENT PARTS-1, HANDLE PARTS-1)
73009	1/4-20 HEXNUT (2)
73011	1/4-20 X 1/2 SET SCREW (2)
73013	1/4-20 X 1 1/4 HEXHEAD BOLT
73017	1/4-20 X 2 1/2 HEXHEAD BOLT
73025	1/4" RIVET (6)
73033	1/4-1/4 X 1 HEX KEY (2)
73101	SPACER (2)
73201	3/8-16 X 1 HEXHEAD BOLT
73203	3/8 FLAT WASHER
73204	3/8 SPLIT LOCK WASHER (COVER PARTS-5, WEIGHT PARTS-5, PULLEY PARTS-1, BEARING PARTS-4, MOTOR MOUNTING PARTS-4, FRONT PLATE PARTS-3)
73205	3/8-16 X 3/4 HEXHEAD BOLT (COVER PARTS-5, MOTOR MOUNTING PARTS-8)
73206	3/8-16 X 1 1/4 HEXHEAD BOLT (WEIGHT PARTS-5, BEARING PARTS-4)
73207	3/8-16 NYLON LOCK NUT (4)
73208	3/8-16 X 1 1/2 HEXHEAD BOLT (3)
73210	3/8 INTERNAL/EXTERNAL STAR WASHER (4)
73240	3/8-16 T-BOLT (2)
73260	3/8 90° CONNECTOR
73261	3/8 STRAIGHT CONNECTOR
73302	5/16 FLAT WASHER (2)
73303	5/16 SPLIT LOCK WASHER (2)
73305	5/16-18 X 3/4 HEXHEAD BOLT (2)
73402	1/2-13 LOCK NUT (2)
73404	1/2 FLAT WASHER (2)
73407	1/2-13 X 1 1/2 HEXHEAD BOLT (2)
74401	10-32 X 1/4 PHILLIPS HEAD MACHINE SCREW (2)
74507	6-32 X 1/4 PHILLIPS HEAD MACHINE SCREW (8)
74508	6-32 X 1/2 PHILLIPS PAN HEAD MACHINE SCREW (2)
80101	HANDLE END CAP (ROUND) (2)
80110	HANDLE GRIP (2)

## PLATES & ATTACHMENTS

<u>PART #</u>	<u>DESCRIPTION</u>
6000-2	CLUTCH PLATE
7262	15" GRIND & SCRAPE™ PLATE-INCLUDES SIX CARBIDE HOLDERS W/ CHIPS
7262-1	15" GRIND & SCRAPE™ PLATE-INCLUDES SIX HOLDERS W/ CHIPS, THREE DIAMOND GRINDING PLUGS & THREE DIAMOND GRINDING DISCS
7263	11" GRIND & SCRAPE™ PLATE-INCLUDES THREE CARBIDE HOLDERS W/ CHIPS
7265-C	DIAMOND GRINDING PLUG-COARSE
7265-F	DIAMOND GRINDING PLUG-FINE
7265-M	DIAMOND GRINDING PLUG-MEDIUM

# COMPLETE PARTS LIST

## PLATES & ATTACHMENTS (continued)

<u>PART #</u>	<u>DESCRIPTION</u>
7266-A	DIAMOND GRINDING DISC ASSEMBLY
7266-C	DIAMOND GRINDING DISC-COARSE
7266-2	GRINDING DISC MOUNTING POST
7266-3	GRINDING DISC MOUNTING POST RETAINER CLIP
7266-4	GRINDING DISC MOUNTING BOLT
7266-5	GRINDING DISC MOUNTING WASHER
7267	THREE POSITION CARBIDE HOLDER
7267-1	CARBIDE HOLDER MOUNTING BOLT (NOT SHOWN)
7268	EIGHT SIDED CARBIDE REPLACEMENT CHIP
7268-1	CARBIDE CHIP FASTENING SCREW (NOT SHOWN)
71221	GRINDING DISC BEARING (NOT SHOWN)
73317	5/16-18 X 1½ FLAT HEAD SCREW (4)
73501	5/8-11 X 1 CUP POINT SET SCREW

## LABEL LIST

<u>PART #</u>	<u>DESCRIPTION</u>
L49	POWER CORD LABEL
L104A	MOVING PARTS LABEL
L104B	READ AND UNDERSTAND INSTRUCTIONS LABEL
L104C	NEVER OPERATE WITHOUT RUBBER DUST GUARD LABEL (3)
L104D	PROPERLY GROUNDED LABEL
L104E	DO NOT RUN DISC LABEL (2)
L104F	ROTATION LABEL (2)
L105	SAFE OPERATING TIPS LABEL
L141E	MADE IN USA LABEL
L175	NATIONAL LABEL, SMALL
L176	NATIONAL LABEL, LARGE
L265	SILICA DUST LABEL

# PART NUMBERS & DIAGRAMS

## FRAME & SHROUD PARTS

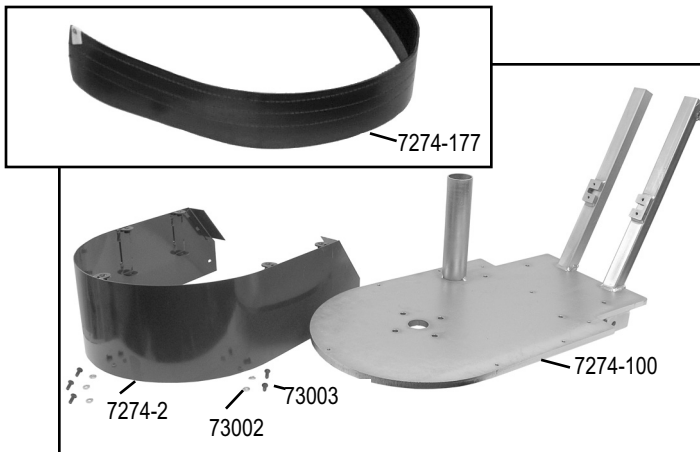

<u>PART #</u>	<u>DESCRIPTION</u>
6274-178A	Rubber Guard Mounting Velcro Loop Side 50" (Not Shown)
6274-178B	Rubber Guard Mounting Velcro for Shroud, Hook Side 50" (Not Shown)
7274-2	Shroud
7274-100	Base Plate
7274-177	Rubber Guard(w/ Loop Velcro)
73002	1/4 Split Washer (5)
73003	1/4-20 x 5/8 Button Head Screw (5)

## COVER PARTS

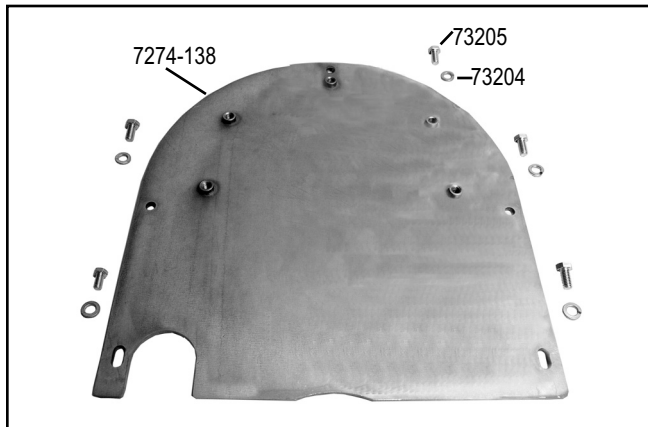

<u>PART #</u>	<u>DESCRIPTION</u>
7274-138	Cover
73204	3/8 Split Lock Washer (5)
73205	3/8-16 x 3/4 Hexhead Bolt (5)

## WEIGHT PARTS

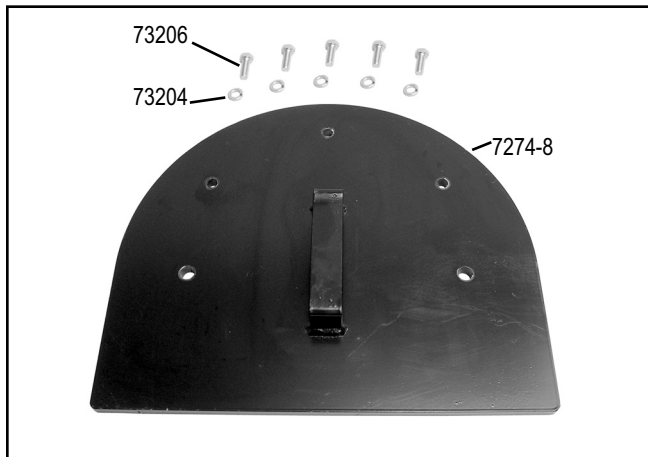

<u>PART #</u>	<u>DESCRIPTION</u>
7274-8	Top Weight
73204	3/8 Split Lock Washer (5)
73206	3/8-16 x 1-1/4 Hexhead Bolt (5)

# PART NUMBERS & DIAGRAMS

## PULLEY PARTS

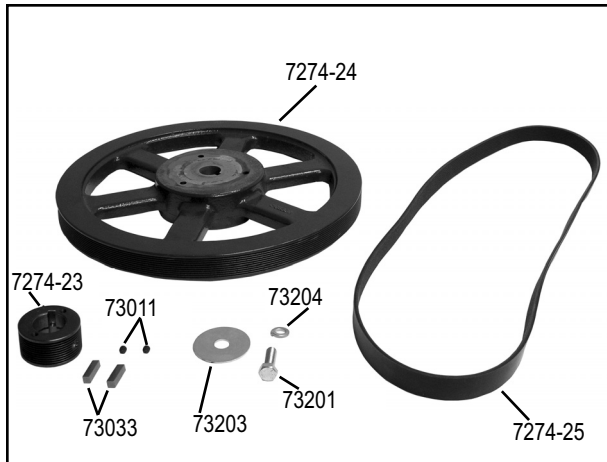

<u>PART #</u>	<u>DESCRIPTION</u>
7274-23	Small Pulley
7274-24	Large Pulley
7274-25	Belt 520J10
73011	1/4-20 x 1/2 Set Screw (2)
73033	1/4-1/4 x 1 Hex Key (2)
73201	3/8-16 x 1 Hexhead Bolt
73203	3/8 Flat Washer
73204	3/8 Split Lock Washer

## BEARING PARTS

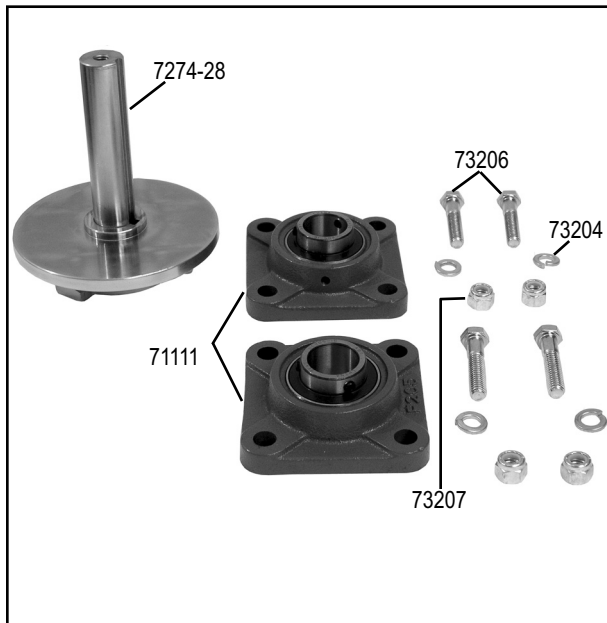

<u>PART #</u>	<u>DESCRIPTION</u>
7274-28	Grinder Hub
71111	Flange Bearing (2)
73204	3/8 Split Lock Washer (4)
73206	3/8-16 x 1-1/4 Hexhead Bolt (4)
73207	3/8 Nylon Lock Nut (4)



# PART NUMBERS & DIAGRAMS

## MOTOR PARTS

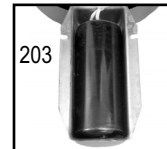
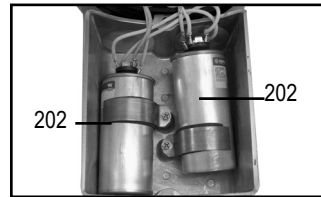
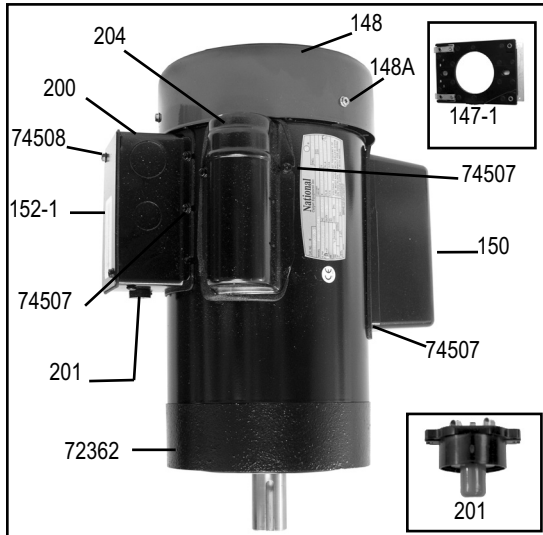

<u>PART #</u>	<u>DESCRIPTION</u>
6280-147-1	Starter Switch
6280-148	Motor Fan Cover
6280-148A	Motor Fan Cover Screw (3)
6280-149	Motor Fan (Not Shown)
6280-150	Capacitor Cover
6280-152	Motor Junction Box Only (Not Shown)
6280-152-1	Motor Junction Box Cover Only
6280-152-3	Motor Junction Cover Gasket (Not Shown)
6280-152-4	Motor Junction Box Frame Gasket (Not Shown)

<u>PART #</u>	<u>DESCRIPTION</u>
6280HD-200	Motor Junction Box
74508	6-32 x 1/2 Phillips Pan Head Machine Screw (2)
6280HD-201	Thermo-Overload Switch
6280HD-202	Motor Capacitor (Run) (2)
6280HD-203	Motor Capacitor (Start)
6280HD-204	Capacitor Cover
6280HD-204A	Capacitor Cover Gasket (Not Shown)
74507	6-32 x 1/4 Phillips Head Machine Screw (8)
72362	Motor 115 Volt

## MOTOR MOUNTING PARTS

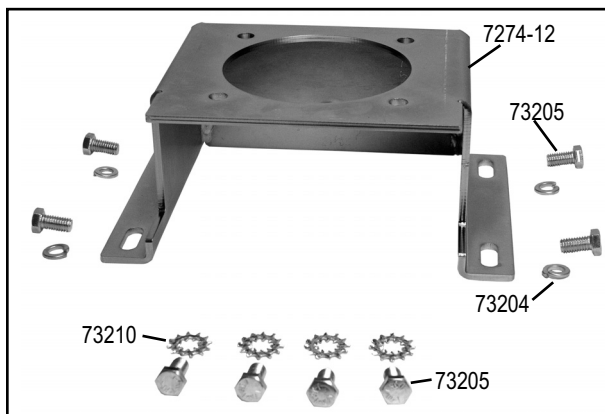

<u>PART #</u>	<u>DESCRIPTION</u>
7274-12	Motor Mount
73204	3/8 Split Lock Washer (4)
73205	3/8-16 x 3/4 Hexhead Bolt (8)
73210	3/8 Internal/External Star Washer (4)

# PART NUMBERS & DIAGRAMS

## ADJUSTMENT PARTS

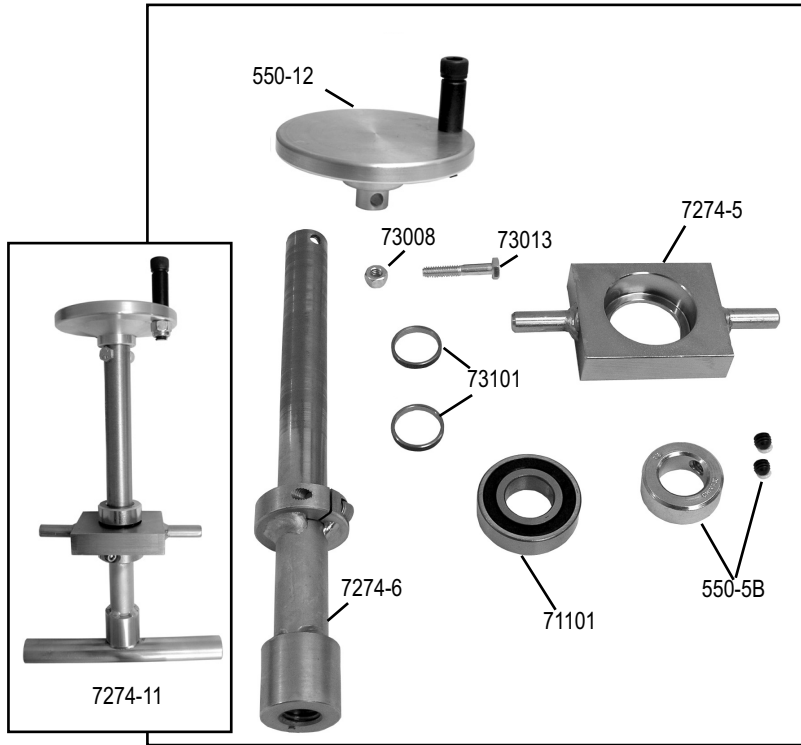

<u>PART #</u>	<u>DESCRIPTION</u>
550-5B	Shaft Collar 7/8"
550-12	Adjustment Wheel w/ Handle Only
7274-5	Bearing Plate
7274-6	Adjustment Shaft
7274-11	Adjustment Wheel Assembly
71101	Bearing 7/8"
73008	1/4-20 Nylock Nut
73013	1/4-20 x 1-1/4 Hexhead Bolt
73101	Spacer (2)

## BEARING PLATE SECURING MOUNTS

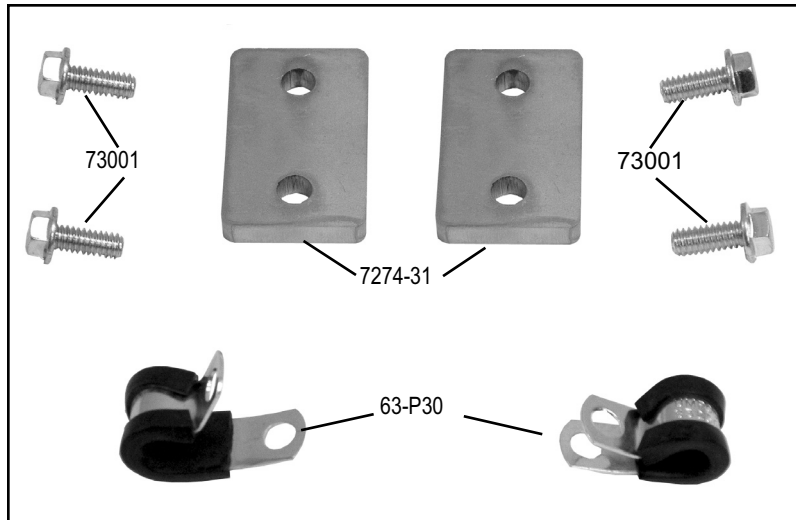

<u>PART #</u>	<u>DESCRIPTION</u>
63-P30	3/8" Small Wire Clamp (2)
7274-31	Bracket Cover (2)
73001	1/4-20 x 1/2 Wizlock Bolt (4)

# PART NUMBERS & DIAGRAMS

## BASE PARTS

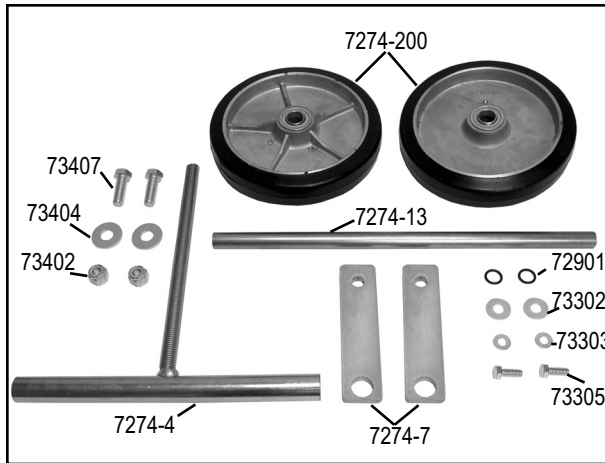

<u>PART #</u>	<u>DESCRIPTION</u>
7274-4	Adjustment T-Bar
7274-7	Wheel Legs (2)
7274-13	Axle
7274-200	Wheel (2)
72901	O Ring - #113
73302	5/16 Flat Washer (2)
73303	5/16 Split Lock Washer (2)
73305	5/16-18 x 3/4 Hexhead Bolt (2)
73402	1/2-13 Lock Nut (2)
73404	1/2 Flat Washer (2)
73407	1/2-13 x 1-1/2 Hexhead Bolt (2)

## REAR BRACKET

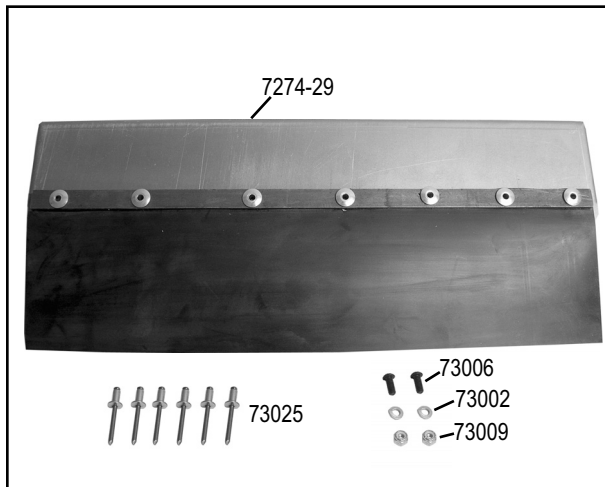

<u>PART #</u>	<u>DESCRIPTION</u>
7274-29	Rear Bracket Assembly
73002	1/4 Split Washer (2)
73006	1/4-20 x 3/4 Button Head Screw (2)
73009	1/4-20 Hexnut (2)
73025	1/4" Rivet (6)

# PART NUMBERS & DIAGRAMS

## HANDLE PARTS

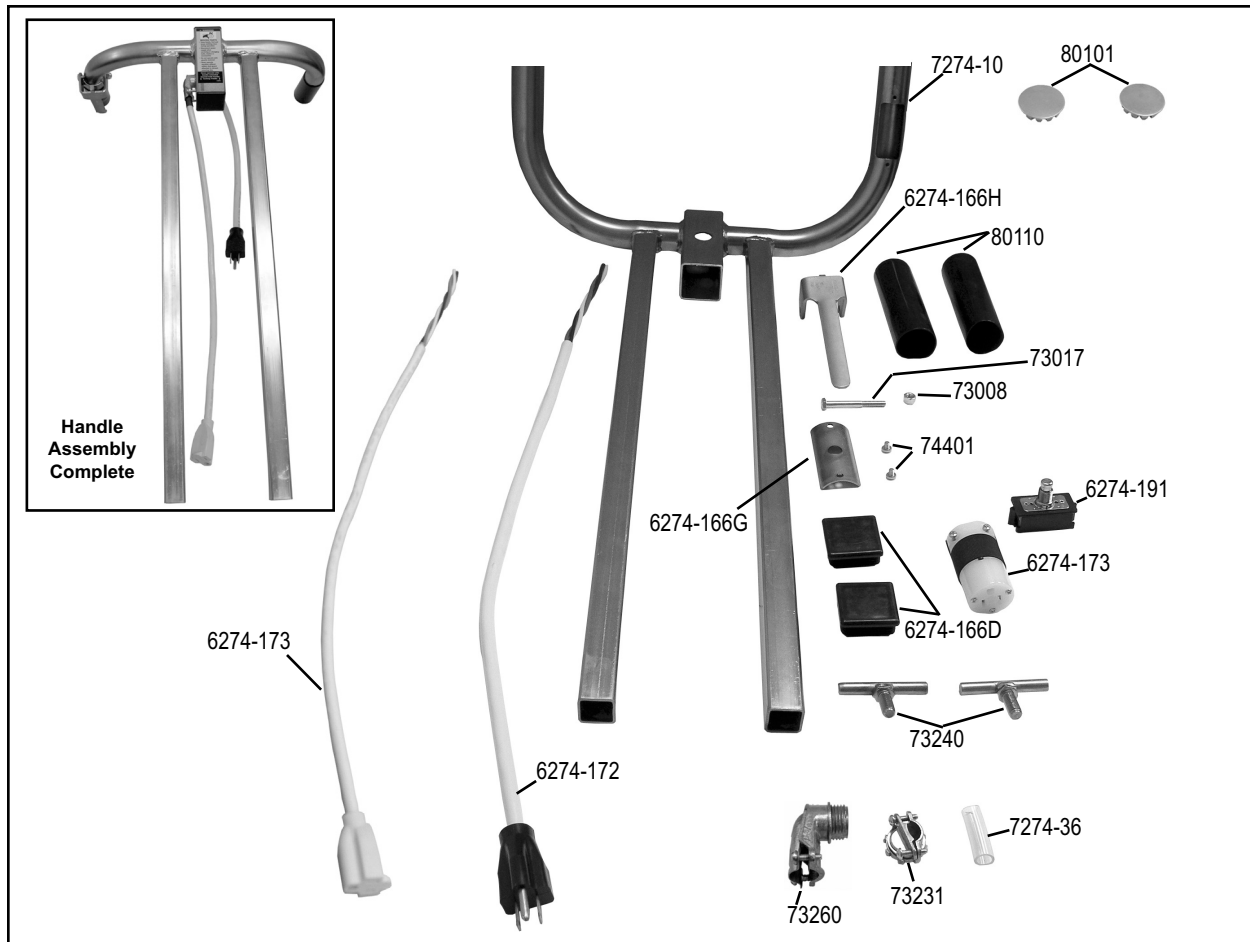

<b>PART #</b>	<b>DESCRIPTION</b>	<b>PART #</b>	<b>DESCRIPTION</b>
6274-166	Handle Wired Complete (Not Shown)	7274-36	1" Plastic Tube
6274-166D	Handle End Cap (Square) (2)	73008	1/4-20 Nylock Nut
6274-166G	Handle Switch Plate	73017	1/4-20 x 2-1/2 Hexhead Bolt
6274-166H	Handle Control Lever	73240	3/8-16 T-Bolt (2)
6274-171	Power Cord	73260	3/8 90° Connector
6274-172	Power Cord - Male Plug	73261	3/8 Straight Connector
6274-173	Handle Cord - Female Plug	74401	10-32 x 1/4 Phillips Head Machine Screw (2)
6274-191	Handle Switch	80101	Handle End Cap (Round) (2)
7274-10	Handle Bar Assembly	80110	Handle Grip (2)

# PART NUMBERS & DIAGRAMS

## FRONT PLATE PARTS

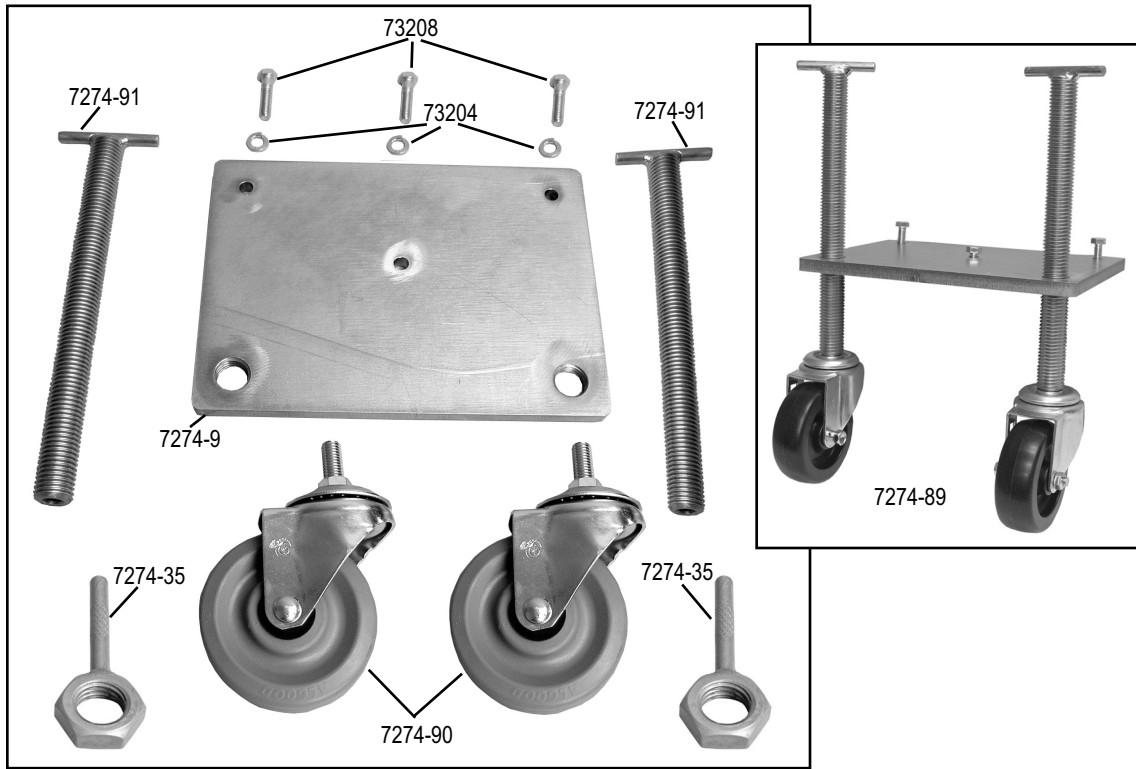

<b>PART #</b>	<b>DESCRIPTION</b>
7274-9	Front Wheel Bracket
7274-35	Jamb Nut (2)
7274-89	Front Wheel Assembly
7274-90	Caster Wheel (2)

<b>PART #</b>	<b>DESCRIPTION</b>
7274-91	Front Adjustment Rod (2)
73204	3/8 Split Lock Washer (3)
73208	3/8-16 x 1-1/2 Hexhead Bolt (3)

# GRIND & SCRAPE™ PLATES & ATTACHMENTS

## GRIND & SCRAPE™ PLATES

- #6000-2      **Clutch Plate**
- #7262        **15" Grind & Scrape™ Plate-** includes six Carbide Holders with Chips
- #7262-1      **15" Grind & Scrape™ Plate-** includes six Carbide Holders with Chips, three Diamond Grinding Plugs and three Diamond Grinding Discs
- #7263        **11" Grind & Scrape™ Plate-** includes three Carbide Holders with Chips
- #73317       **5/16-18 x 1½ Flat Head Screw (4)**
- #73335       **5/16 Allen Wrench**
- #73501       **5/8-11 x 1 Cup Point Set Screw**

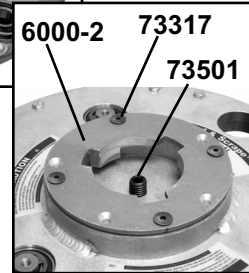
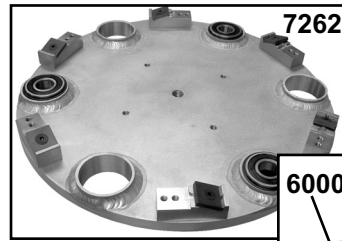

## #7266 DIAMOND GRINDING DISCS

*Eliminates swirl marks*

Unique planetary diamond grinding disc rotates on heavy-duty sealed bearings which allow the disc to rotate in the opposite direction of the plate eliminating "swirl marks" in concrete surfaces. Presents the same result as a planetary grinder costing thousands of dollars more. Gives the surface of the floor a fantastic finish for sealing, painting or staining. Three grits to choose from.

- #7266-A      **Diamond Grinding Disc Assembly**
- #7266-C      **Diamond Grinding Disc Coarse**
- #7266-1      **Grinding Disc Bearing (Not Shown)**
- #7266-2      **Grinding Disc Mounting Post**
- #7266-3      **Grinding Disc Mounting Post Retainer Clip**
- #7266-4      **Grinding Disc Mounting Bolt**
- #7266-5      **Grinding Disc Mounting Washer**



## #7265 DIAMOND GRINDING PLUG

Diamond grinding plugs for aggressive grinding. Evens out, smooths or decontaminates concrete surfaces. Three grits to choose from.

- #7265-C      **Diamond Grinding Plug Coarse**
- #7265-F      **Diamond Grinding Plug Fine**
- #7265-M      **Diamond Grinding Plug Medium**



7265

## #7267 THREE POSITION CARBIDE HOLDER

This unique three-position carbide mount allows operator to set carbides to optimum performance. For scraping all types of adhesives, removing this-set mortar, epoxy, urethane, thin coatings, elastomers, paint, etc. Large 1", eight-sided carbide grinding chip.

- #7267        **Three Position Carbide Holder**
- #7267-1      **Carbide Holder Mounting Bolt (Not Shown)**
- #7268        **Eight Sided Carbide Replacement Chip**
- #7268-1      **Carbide Chip Fastening Screw (Not Shown)**

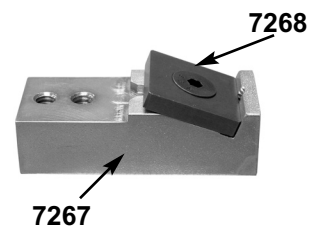

# LABELS

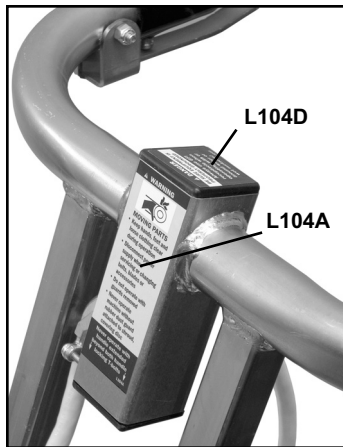
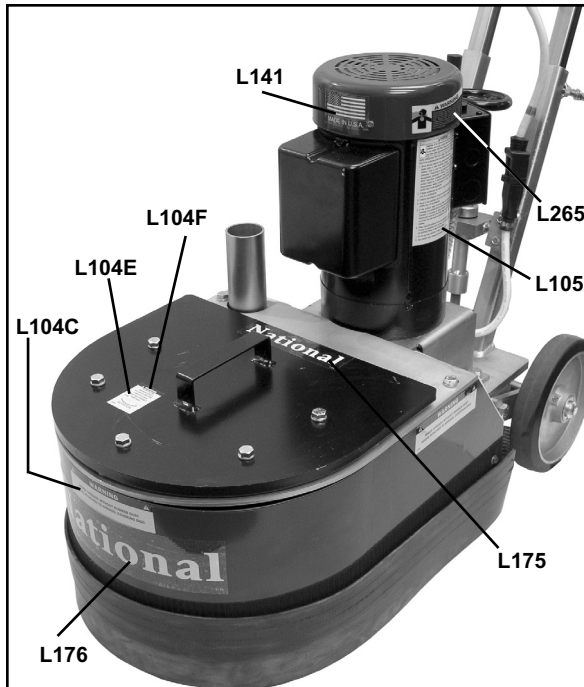

## LABEL LIST

<b>PART #</b>	<b>DESCRIPTION</b>	<b>PART #</b>	<b>DESCRIPTION</b>
L49	Power Cord Label	L104F	Rotation Label (2)
L104A	Moving Parts Label	L105	Safe Operating Tips Label
L104B	Read and Understand Instructions Label	L141E	Made in USA Label
L104C	Never Operate Without Rubber Dust Guard Label (3)	L175	National Label, Small
L104D	Properly Grounded Label	L176	National Label, Large
L104E	Do Not Run Disc Label (2)	L265	Silica Dust Label

# GUARANTEE

National Carpet Equipment, Inc. (National) warrants to the first consumer/purchaser that this National brand product (the #7274 Panther Single Disc Grind & Scrape), when shipped in its original container, will be free from defective workmanship and materials and agrees that it will, at its option, either repair the defect or replace the defective product or part thereof at no charge to the purchaser for parts or labor for the period(s) set forth below.

This warranty does not apply to any appearance items of the product, to the additional excluded items set forth below, or to any product, the exterior of which has been damaged or defaced, which has been subjected to misuse, abnormal service or handling, or which has been altered or modified in design or construction.

In order to enforce the rights under this limited warranty, the purchaser should follow the steps set forth below and provide proof of purchase to National.

The limited warranty described herein is in addition to whatever implied warranties may be granted to purchasers by law. **ALL IMPLIED WARRANTIES INCLUDING THE WARRANTIES OF MERCHANTABILITY AND FITNESS FOR USE ARE LIMITED TO THE PERIODS FROM THE DATE OF PURCHASE AS SET FORTH BELOW.** Some states do not allow time limitations on an implied warranty, so the above limitation may not apply to you.

Neither the sales person of the seller, nor any other person, is authorized to make any other warranties other than those described herein, or to extend the duration of any warranties beyond the time period described herein on behalf of National.

The warranties described herein shall be the sole and exclusive warranties granted by National and shall be the sole and exclusive remedy available to the purchaser. Correction of defects in the manner and for the period of time described herein, shall constitute complete fulfillment of all liabilities and responsibilities of National to the purchaser with respect to the product and shall constitute full satisfaction of all claims, whether based on contract, negligence, strict liability or otherwise. In no event shall National be liable, or in any way responsible for any damage or defects in the product which were caused by repairs or attempted repairs performed by anyone other than National. Nor shall National be liable, or in any way responsible, for any incidental or consequential, economics or property damage. Some states do not allow the exclusion of incidental or consequential damages, so the above exclusion may not apply to you.

**THIS WARRANTY GIVES YOU SPECIFIC LEGAL RIGHTS. YOU MAY ALSO HAVE OTHER RIGHTS WHICH VARY FROM STATE TO STATE.**

## **WARRANTY PERIOD**

The National Floor Prep System is guaranteed to be free of manufacturer defective workmanship and in quality of materials for a period of one year.

Items excluded from warranty coverage, unless found and reported defective immediately upon removal from the original shipping container and before being used by the original purchaser.

A freight damage claim must be filed with the carrier by the purchaser, the shipper cannot file the freight claim.

To obtain service contact National Carpet Equipment, Inc. toll free at 800-245-0267 for a repair authorization number. COD freight returns will not be accepted. Freight collect shipments will not be accepted. Warranty repairs must be accompanied by date of purchase receipt and a return/repair authorization number.



# RETURN SHEET

Company Name \_\_\_\_\_

Contact Name \_\_\_\_\_

Telephone Number \_\_\_\_\_

Approximate Usage (hours) \_\_\_\_\_

Problems Encountered \_\_\_\_\_

\_\_\_\_\_

\_\_\_\_\_

\_\_\_\_\_

\_\_\_\_\_

Check One:  Repair

Do you wish to be contacted before repairing  Yes  No

Return

Contact National if a loaner is needed

Return Authorization Number \_\_\_\_\_ Date \_\_\_\_\_  
required, contact National

Customer Number \_\_\_\_\_  
if known

Purchased From \_\_\_\_\_  
if not directly from National

<b>INTERNAL USE ONLY</b>
Date Received _____
Unit Serial Number _____
Subject To Warranty _____